

OPEN END (OE)

1¹/₁₆" Common Centerline / 36.5 mm Common Centerline

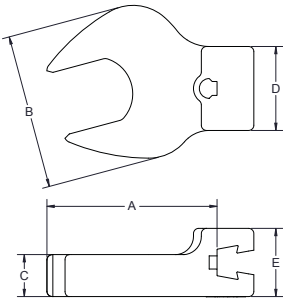

Part No.	Model	Size	A (in.)	B (in.)	C (in.)	D (in.)	E (in.)	Max Torque (in. lbs.)
819000	OE - 1/4	1/4	1 ⁵ / ₈	3/4	1/4	3/4	1 ¹ / ₁₆	100
819001	OE - 5/16	5/16	1 ⁵ / ₈	3/4	1/4	3/4	1 ¹ / ₁₆	150
819002	OE - 3/8	3/4	1 ¹³ / ₁₆	1 ¹ / ₁₆	5/16	3/4	1 ¹ / ₁₆	200
819003	OE - 7/16	7/16	1 ¹³ / ₁₆	1 ¹ / ₁₆	5/16	3/4	1 ¹ / ₁₆	300
819004	OE - 1/2	1/2	1 ¹⁵ / ₁₆	1 ⁵ / ₁₆	1 ³ / ₃₂	3/4	1 ¹ / ₁₆	350
819005	OE - 9/16	9/16	1 ¹⁵ / ₁₆	1 ⁵ / ₁₆	1 ³ / ₃₂	3/4	1 ¹ / ₁₆	400
819006	OE - 5/8	5/8	1 ¹⁵ / ₁₆	1 ¹⁹ / ₃₂	7/16	7/8	1 ¹ / ₁₆	600
819007	OE - 11/16	1 ¹ / ₁₆	1 ¹⁵ / ₁₆	1 ¹⁹ / ₃₂	7/16	7/8	1 ¹ / ₁₆	800
819008	OE - 3/4	3/4	2	1 ²⁷ / ₃₂	1/2	1	1 ³ / ₁₆	1000
819009	OE - 13/16	1 ³ / ₁₆	2	1 ²⁷ / ₃₂	1/2	1	1 ³ / ₁₆	1250
819010	OE - 7/8	7/8	2	2 ¹ / ₈	1/2	1 ¹ / ₄	1 ³ / ₁₆	1500
819011	OE - 15/16	1 ⁵ / ₁₆	2	2 ¹ / ₈	1/2	1 ¹ / ₄	1 ³ / ₁₆	1750
819012	OE - 1	1	2 ³ / ₈	2 ⁵ / ₁₆	1/2	1 ¹ / ₄	1 ³ / ₁₆	2000
819013	OE - 1 1/16	1 ¹ / ₁₆	2 ³ / ₈	2 ⁵ / ₁₆	1/2	1 ¹ / ₄	1 ³ / ₁₆	2250
819014	OE - 1 1/8	1 ¹ / ₈	2 ⁵ / ₁₆	2 ³ / ₄	1/2	1 ¹ / ₄	1 ³ / ₁₆	2500
819015	OE - 1 3/16	1 ³ / ₁₆	2 ⁵ / ₁₆	2 ³ / ₄	1/2	1 ¹ / ₄	1 ³ / ₁₆	2750
819016	OE - 1 1/4	1 ¹ / ₄	2 ⁵ / ₁₆	2 ³ / ₄	1/2	1 ¹ / ₄	1 ³ / ₁₆	3000

OPEN END (OE)

3³/₈" Common Centerline / 98.4mm Common Centerline

Part No.	Model	Size	A (in.)	B (in.)	C (in.)	D (in.)	E (in.)	Max Torque (in. lbs.)
819724	OE-1 ¹ / ₁₆	1 ¹ / ₁₆	4 ⁵ / ₈	2 ⁵ / ₁₆	5/8	1 ¹ / ₂	1	4800
819725	OE-1 ¹ / ₈	1 ¹ / ₈	4 ³⁹ / ₆₄	2 ⁵ / ₁₆	5/8	1 ¹ / ₂	1	4800
819726	OE-1 ¹ / ₄	1 ¹ / ₄	4 ³⁹ / ₆₄	2 ⁵ / ₁₆	5/8	1 ¹ / ₂	1	4800
819727	OE-1 ¹ / ₂	1 ¹ / ₂	4 ¹⁹ / ₃₂	2 ⁵ / ₁₆	5/8	1 ¹ / ₂	1	4800
819728	OE-1 ³ / ₄	1 ³ / ₄	4 ³⁷ / ₆₄	2 ⁵ / ₁₆	5/8	1 ¹ / ₂	1	4800
819729	OE-1 ⁵ / ₈	1 ⁵ / ₈	4 ⁹ / ₁₆	2 ⁵ / ₁₆	5/8	1 ¹ / ₂	1	4800
819730	OE-1 ¹¹ / ₁₆	1 ¹¹ / ₁₆	4 ⁹ / ₁₆	2 ⁵ / ₁₆	5/8	1 ¹ / ₂	1	4800
819731	OE-1 ³ / ₄	1 ³ / ₄	4 ³⁵ / ₆₄	2 ⁵ / ₁₆	5/8	1 ¹ / ₂	1	4800
819732	OE-1 ¹³ / ₁₆	1 ¹³ / ₁₆	4 ³³ / ₆₄	2 ⁵ / ₁₆	5/8	1 ¹ / ₂	1	4800
819733	OE-1 ⁷ / ₈	1 ⁷ / ₈	4 ¹⁵ / ₁₆	4 ¹ / ₃₂	5/8	1 ¹ / ₂	1	4800
819734	OE-1 ¹⁵ / ₁₆	1 ¹⁵ / ₁₆	4 ⁹³ / ₁₀₀	4 ¹ / ₃₂	5/8	1 ¹ / ₂	1	4800
819735	OE-2	2"	4 ⁵⁹ / ₆₄	4 ¹ / ₃₂	5/8	1 ¹ / ₂	1	4800
819736	OE-2 ¹ / ₁₆	2 ¹ / ₁₆	4 ²⁹ / ₃₂	4 ¹ / ₃₂	5/8	1 ¹ / ₂	1	4800
819737	OE-2 ¹ / ₈	2 ¹ / ₈	4 ²⁹ / ₃₂	4 ¹ / ₃₂	5/8	1 ¹ / ₂	1	4800
819738	OE-2 ³ / ₁₆	2 ³ / ₁₆	4 ⁹ / ₁₀	4 ¹ / ₃₂	5/8	1 ¹ / ₂	1	4800
819739	OE-2 ¹ / ₄	2 ¹ / ₄	4 ⁷ / ₈	4 ¹ / ₃₂	5/8	1 ¹ / ₂	1	4800
819740	OE-2 ⁵ / ₁₆	2 ⁵ / ₁₆	4 ⁷ / ₅	4 ¹ / ₃₂	5/8	1 ¹ / ₂	1	4800
819741	OE-2 ³ / ₈	2 ³ / ₈	4 ⁵⁵ / ₆₄	4 ¹ / ₃₂	5/8	1 ¹ / ₂	1	4800
819742	OE-2 ¹ / ₂	2 ¹ / ₂	4 ²⁷ / ₃₂	4 ¹ / ₃₂	5/8	1 ¹ / ₂	1	4800
819743	OE-2 ¹ / ₂	2 ¹ / ₂	4 ⁵³ / ₆₄	4 ¹ / ₃₂	5/8	1 ¹ / ₂	1	4800
819744	OE-2 ⁹ / ₁₆	2 ⁹ / ₁₆	4 ¹³ / ₁₆	4 ¹ / ₃₂	5/8	1 ¹ / ₂	1	4800
819745	OE-2 ⁵ / ₈	2 ⁵ / ₈	4 ⁵¹ / ₆₄	4 ¹ / ₃₂	5/8	1 ¹ / ₂	1	4800
819746	OE-2 ¹¹ / ₁₆	2 ¹¹ / ₁₆	5 ³¹ / ₆₄	5 ⁵ / ₈	5/8	1 ¹ / ₂	1	4800
819747	OE-2 ³ / ₄	2 ³ / ₄	5 ³¹ / ₆₄	5 ⁵ / ₈	5/8	1 ¹ / ₂	1	4800
819748	OE-2 ¹³ / ₁₆	2 ¹³ / ₁₆	5 ³¹ / ₆₄	5 ⁵ / ₈	5/8	1 ¹ / ₂	1	4800
819749	OE-2 ⁷ / ₈	2 ⁷ / ₈	5 ³¹ / ₆₄	6	5/8	1 ¹ / ₂	1	4800
819750	OE-2 ¹⁵ / ₁₆	2 ¹⁵ / ₁₆	5 ³¹ / ₆₄	6	5/8	1 ¹ / ₂	1	4800
819751	OE-3	3	5 ³¹ / ₆₄	6	5/8	1 ¹ / ₂	1	4800
819752	OE-3 ¹ / ₄	3 ¹ / ₄	5 ¹³ / ₃₂	6	5/8	1 ¹ / ₂	1	4800

OPEN END (OE)

1 $\frac{1}{16}$ " Common Centerline / 36.5 mm Common Centerline

Part No.	Model	Size (mm)	A (mm)	B (mm)	C (mm)	D (mm)	E (mm)	Torque Rating (Nm)
809294	OE-5 mm	5	43.18	20.32	7.62	20.32	17.78	8
809290	OE-6 mm	6	43.18	20.32	7.62	20.32	17.78	9
809291	OE-7 mm	7	43.18	20.32	7.62	20.32	17.78	11
809292	OE-8 mm	8	43.18	20.32	7.62	20.32	17.78	16
809293	OE-9 mm	9	45.72	27.94	7.62	20.32	17.78	22
819943	OE-10 mm	10	45.72	27.94	7.62	20.32	17.78	22
819944	OE-11 mm	11	45.72	27.94	7.62	20.32	17.78	34
809226	OE-12 mm	12	48.26	33.02	10.16	20.32	17.78	39
819945	OE-13 mm	13	48.26	33.02	10.16	20.32	17.78	39
819946	OE-14 mm	14	48.26	33.02	10.16	20.32	17.78	45
809227	OE-15 mm	15	48.26	40.64	10.16	22.86	17.78	67
819947	OE-16 mm	16	48.26	40.64	10.16	22.86	17.78	67
819948	OE-17 mm	17	48.26	40.64	10.16	22.86	17.78	79
809228	OE-18 mm	18	48.26	40.64	10.16	22.86	17.78	90
819949	OE-19 mm	19	50.8	45.72	12.70	25.40	17.78	113
819950	OE-21 mm	21	50.8	45.72	12.70	25.40	20.32	140
819951	OE-22 mm	22	50.8	53.34	12.70	33.02	20.32	169
819952	OE-24 mm	24	50.8	53.34	12.70	33.02	20.32	197
809229	OE-27 mm	27	55.88	58.42	12.70	33.02	20.32	254
819956	OE-30 mm	30	58.42	71.12	12.70	33.02	20.32	310
819958	OE-32 mm	32	58.42	71.12	12.70	33.02	20.32	338

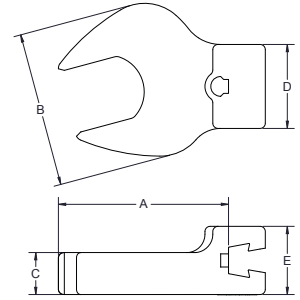

OPEN END (OE)

3 $\frac{3}{16}$ " Common Centerline / 98.4mm Common Centerline

Part No.	Model	Size (mm)	A (mm)	B (mm)	C (mm)	D (mm)	E (mm)	Torque Rating (Nm)
819761	OE-33 mm	33	117.48	74.61	15.88	38.1	25.4	350
819762	OE-34 mm	34	117.48	74.61	15.88	38.1	25.4	350
819763	OE-35 mm	35	117.08	74.61	15.88	38.1	25.4	350
819766	OE-36 mm	36	117.08	74.61	15.88	38.1	25.4	350
819764	OE-37 mm	37	116.68	74.61	15.88	38.1	25.4	400
819765	OE-38 mm	38	116.68	74.61	15.88	38.1	25.4	400
819771	OE-40 mm	40	116.28	74.61	15.88	38.1	25.4	400
819755	OE-41 mm	41	116.28	74.61	15.88	38.1	25.4	400
819769	OE-42 mm	42	115.89	74.61	15.88	38.1	25.4	400
819774	OE-44 mm	44	125.41	110.33	15.88	38.1	25.4	400
853545	OE-46 mm	46	125.41	110.33	15.88	38.1	25.4	400
819770	OE-48 mm	48	124.62	110.33	15.88	38.1	25.4	400
819756	OE-50 mm	50	125.02	110.33	15.88	38.1	25.4	400
819757	OE-55 mm	55	124.22	110.33	15.88	38.1	25.4	400
819753	OE-60 mm	60	123.43	110.33	15.88	38.1	25.4	400

Custom Solutions

In addition to our established line of interchangeable heads, SR is proud to offer custom solutions to meet your unique torque needs. For more information on custom interchangeable heads and other solutions please contact SR customer service world wide at +1 847-455-867

RATCHETING OPEN END (ROE)

1/16" Common Centerline / 36.5 mm Common Centerline
Slight disengagement from the fastener allows operator to rapidly rotate wrench.

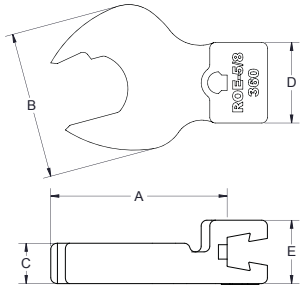

Part No.	Model	Hex Size (in.)	A (in.)	B (in.)	C (in.)	D (in.)	E (in.)	Max Torque (in. lbs.)
819201	ROE - 5/16	5/16	1 41/64	3/4	1/4	3/4	11/16	90
819202	ROE - 3/8	3/8	1 5/8	1 1/16	5/16	3/4	11/16	120
819203	ROE - 7/16	7/16	1 23/32	1 1/16	5/16	3/4	11/16	180
819204	ROE - 1/2	1/2	1 23/32	1 5/16	13/32	3/4	11/16	210
819205	ROE - 9/16	9/16	1 27/32	1 5/16	13/32	3/4	11/16	240
819206	ROE - 5/8	5/8	1 27/32	1 19/32	7/16	3/4	11/16	360
819207	ROE - 11/16	1 1/16	1 7/8	1 19/32	7/16	3/4	11/16	480
819208	ROE - 3/4	3/4	2	1 27/32	1/2	1	13/16	600
819209	ROE - 13/16	13/16	1 31/32	1 27/32	1/2	1	13/16	750
819210	ROE - 7/8	7/8	1 31/32	2 1/8	1/2	1 1/4	1 13/16	900
819211	ROE - 15/16	15/16	1 61/64	2 1/8	13/32	13/16	1 1/4	1050
819214	ROE - 1 1/8	1 1/8	2 19/64	2 1/4	1/2	1 1/4	1 1/4	1500

Part No.	Model	Hex Size (mm)	A (mm)	B (mm)	C (mm)	D (mm)	E (mm)	Max Torque (Nm)
819220	ROE-10 mm	10	43.18	27.94	7.62	20.32	17.78	13
819221	ROE-11 mm	11	43.18	27.94	7.62	20.32	17.78	20
819222	ROE-12 mm	12	45.72	33.02	7.62	20.32	17.78	23
819223	ROE-13 mm	13	45.72	33.02	7.62	20.32	17.78	23
819224	ROE-14 mm	14	45.72	33.02	7.62	20.32	17.78	27
819225	ROE-15 mm	15	45.72	40.64	7.62	22.86	17.78	27
819226	ROE-16 mm	16	45.72	40.64	7.62	22.86	17.78	40
819227	ROE-17 mm	17	45.72	40.64	7.62	22.86	17.78	54
819228	ROE-18 mm	18	45.72	40.64	7.62	22.86	17.78	54
819229	ROE-19 mm	19	48.26	45.72	10.16	25.4	20.32	68
819231	ROE-22 mm	22	50.8	53.34	10.16	33.02	20.32	101
819232	ROE-24 mm	24	50.8	53.34	10.16	33.02	20.32	118
819233	ROE-27 mm	27	53.34	58.42	12.7	33.02	20.32	152

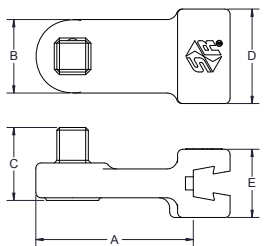

SQUARE DRIVE (SD)

1/16" Common Centerline / 36.5 mm Common Centerline

Part No.	Model	Drive Size (in.)	A (in.)	B (in.)	C (in.)	D (in.)	E (in.)	Max Torque (in. lbs.)
819057	SD - 1/4	1/4	1 3/4	7/8	3/4	5/8	11/16	250
819058	SD - 3/8	3/8	1 7/8	7/8	3/4	5/8	11/16	1250
819059	SD - 1/2	1/2	1 15/16	15/16	3/4	5/8	11/16	2500
819119*	SD - 3/4	3/4	5 5/64	1 1/2	1 3/4	7/8	11/16	4800

*3/8" Common Centerline / 98.4mm Common Centerline

BOX HEAD (BH)

1/16" Common Centerline / 36.5 mm Common Centerline

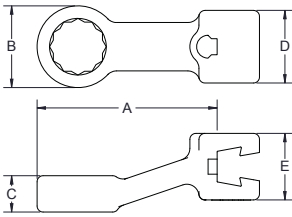

Part No.	Model	Size (in.)	A (in.)	B (in.)	C (in.)	D (in.)	E (in.)	Max Torque (in. lbs.)
819060	BH - 1/4	1/4	1 ⁴⁵ / ₆₄	1 ⁷ / ₃₂	9/32	3/4	1 ¹¹ / ₁₆	250
819061	BH - 5/16	5/16	1 ⁴⁵ / ₆₄	1 ⁷ / ₃₂	9/32	3/4	1 ¹¹ / ₁₆	350
819062	BH - 3/8	3/8	1 ³ / ₄	5/8	9/32	3/4	1 ¹¹ / ₁₆	450
819063	BH - 7/16	7/16	1 1 ¹³ / ₁₆	3/4	2 ³ / ₆₄	3/4	1 ¹¹ / ₁₆	650
819064	BH - 1/2	1/2	1 ⁵⁵ / ₆₄	2 ⁷ / ₃₂	3/8	3/4	1 ¹¹ / ₁₆	850
819065	BH - 9/16	9/16	2	1	1 ³ / ₃₂	7/8	1 ¹¹ / ₁₆	1050
819066	BH - 5/8	5/8	2	1 ¹ / ₁₆	3 ⁵ / ₆₄	1 ⁵ / ₁₆	1 ³ / ₁₆	1250
819067	BH - 11/16	1 ¹ / ₁₆	2	1 ¹ / ₈	1/2	1 ⁵ / ₁₆	1 ³ / ₁₆	1450
819068	BH - 3/4	3/4	2 ¹ / ₁₆	1 ¹ / ₄	3 ⁵ / ₆₄	1	1 ³ / ₁₆	1800
819070	BH - 7/8	7/8	2 ¹ / ₄	1 ⁵ / ₁₆	5/8	1 ¹ / ₄	1 ³ / ₁₆	2400
819071	BH - 15/16	1 ¹⁵ / ₁₆	2 ¹ / ₄	1 ¹ / ₂	2 ¹ / ₃₂	1 ¹ / ₄	1 ³ / ₁₆	2700
819072	BH - 1	1	2 ¹ / ₄	1 ⁹ / ₁₆	2 ³ / ₃₂	1 ¹ / ₄	1 ³ / ₁₆	3000
819073	BH - 1 1/16	1 ¹ / ₁₆	2 ¹ / ₄	2 ¹ / ₁₆	7/8	1 ¹ / ₄	1 ³ / ₁₆	3150
819074	BH - 1 1/8	1 ¹ / ₈	2 ¹ / ₂	2 ¹ / ₁₆	7/8	1 ¹ / ₄	1 ³ / ₁₆	3300
819075	BH - 1 1/4	1 ¹ / ₄	2 ¹ / ₂	2 ¹ / ₁₆	7/8	1 ¹ / ₄	1 ³ / ₁₆	3600

Part No.	Model	Size (mm)	A (mm)	B (mm)	C (mm)	D (mm)	E (mm)	Max. Torque (Nm)
809302	BH-8 mm	8	43.18	12.7	7.62	20.32	20.32	39
809303	BH-9 mm	9	45.72	15.24	7.62	20.32	20.32	50
809230	BH-10 mm	10	45.72	15.24	7.62	20.32	20.32	50
809231	BH-11 mm	11	45.72	20.32	10.16	20.32	20.32	73
809304	BH-12 mm	12	45.72	20.32	10.16	20.32	20.32	96
809232	BH-13 mm	13	45.72	20.32	10.16	20.32	20.32	96
809233	BH-14 mm	14	48.26	25.4	10.16	22.86	20.32	119
809234	BH-15 mm	15	50.8	27.94	12.7	25.4	22.86	141
809305	BH-16 mm	16	50.8	27.94	12.7	25.4	22.86	141
809235	BH-17 mm	17	50.8	27.94	12.7	25.4	22.86	163
809306	BH-18 mm	18	50.8	27.94	12.7	25.4	22.86	163
809236	BH-19 mm	19	53.34	33.02	15.24	25.4	22.86	203
809309	BH-20 mm	20	53.34	33.02	15.24	25.4	22.86	225
809307	BH-21 mm	21	53.34	33.02	15.24	25.4	22.86	237
809308	BH-22 mm	22	55.88	35.56	15.24	33.02	22.86	271
809237	BH-24 mm	24	55.88	35.56	17.78	33.02	22.86	305
809352	BH-27 mm	27	55.88	40.64	17.78	33.02	22.86	355

Dovetail vs. Quick Change Wrenches

Dovetail wrenches use our CART tool to change heads. Quick Change versions require only your thumb.

These heads are available on the Exacta 2 1100, 1200, and 1250 Series digital torque wrenches.



FLARE NUT (FN)

1/16" Common Centerline / 36.5 mm Common Centerline

Part No.	Model	Size (in.)	A (in.)	B (in.)	C (in.)	D (in.)	E (in.)	F (in.)	Max Torque (in. lbs.)
819025	FN-1/4	1/4	1 ³ / ₄	5/8	1 ¹ / ₃₂	3/4	1 ¹ / ₁₆	3/16	100
819026	FN-5/16	5/16	1 ¹³ / ₁₆	5/8	2 ³ / ₆₄	3/4	1 ¹ / ₁₆	3/16	150
819027	FN-3/8	3/8	1 ⁵⁵ / ₆₄	2 ⁷ / ₃₂	3/8	3/4	1 ¹ / ₁₆	9/32	200
819028	FN-7/16	7/16	1 ⁵⁵ / ₆₄	2 ⁷ / ₃₂	3/8	3/4	1 ¹ / ₁₆	1 ¹ / ₃₂	250
819029	FN-1/2	1/2	1 ³¹ / ₃₂	1 ¹ / ₁₆	1 ³ / ₃₂	7/8	1 ¹ / ₁₆	3/8	300
819030	FN-9/16	9/16	1 ³¹ / ₃₂	1 ¹ / ₁₆	1 ⁵ / ₃₂	1	1 ³ / ₁₆	7/16	350
819031	FN-5/8	5/8	2	1 ¹ / ₈	1 ⁷ / ₃₂	1	1 ³ / ₁₆	1 ⁷ / ₃₂	400
819032	FN-11/16	11/16	2 ¹ / ₁₆	1 ⁵ / ₁₆	3 ⁵ / ₆₄	1	1 ³ / ₁₆	1 ⁷ / ₃₂	475
819033	FN-3/4	3/4	2 ¹ / ₁₆	1 ⁵ / ₁₆	3 ⁵ / ₆₄	1	1 ³ / ₁₆	1 ⁷ / ₃₂	600
819034	FN-13/16	13/16	2 ¹ / ₄	1	5/8	1 ¹ / ₄	1 ³ / ₁₆	5/8	700
819035	FN-7/8	7/8	2 ¹ / ₄	1 ¹ / ₂	2 ¹ / ₃₂	1 ¹ / ₄	1 ³ / ₁₆	1 ¹ / ₁₆	800
819036	FN-15/16	15/16	2 ³ / ₈	1 ⁹ / ₁₆	2 ³ / ₃₂	1 ¹ / ₄	1 ³ / ₁₆	2 ³ / ₃₂	900
819037	FN-1	1	2 ¹ / ₂	1 ⁹ / ₁₆	2 ³ / ₃₂	1 ¹ / ₄	1 ³ / ₁₆	3/4	1000
819038	FN-1 1/16	1 1/16	2 ¹ / ₂	1 ⁹ / ₁₆	7/8	1 ¹ / ₄	1 ³ / ₁₆	3/4	1050

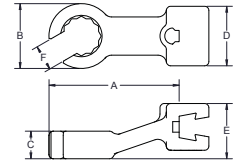

Part No.	Model	Size (mm)	A (mm)	B (mm)	C (mm)	D (mm)	E (mm)	F (mm)	Max Torque (Nm)
809243	FN-8 mm	8	45.72	20.32	10.16	20.32	20.32	7.62	16
809217	FN-9 mm	9	45.72	20.32	10.16	20.32	20.32	7.62	19
809218	FN-10 mm	10	45.72	20.32	10.16	20.32	20.32	7.62	22
809221	FN-11 mm	11	45.72	20.32	10.16	20.32	20.32	7.62	28
809241*	FN-12 mm	12	48.26	25.40	10.16	22.86	20.32	10.16	30
809219	FN-13 mm	13	48.26	25.40	10.16	22.86	20.32	10.16	33
809220	FN-14 mm	14	50.80	27.94	12.70	25.40	20.32	10.16	40
809222	FN-15 mm	15	50.80	27.94	12.70	25.40	20.32	10.16	45
809238	FN-16 mm	16	50.80	27.94	12.70	25.40	20.32	12.70	50
809223	FN-17 mm	17	53.34	33.02	15.24	25.40	20.32	12.70	54
809239	FN-18 mm	18	53.34	33.02	15.24	25.40	20.32	15.24	61
809224	FN-19 mm	19	53.34	33.02	15.25	25.40	20.32	15.24	68
809240	FN-21 mm	21	53.34	38.10	17.78	33.02	20.32	17.78	80
809242	FN-22 mm	22	55.88	38.10	17.78	33.02	20.32	17.78	90
809225	FN-24 mm	24	55.88	40.64	17.78	33.02	20.32	17.78	105

*6 Pt Hex

What is the Common Centerline and why is it important?

<http://www.srtorque.com/resources/understanding-the-common-centerline/>

Custom Solutions

In addition to our established line of interchangeable heads, SR offers custom solutions to meet your unique torque needs. For more information on custom heads and other solutions please contact SR customer service world wide at +1 847-455-867



SQUARE DRIVE RATCHET (SDRT)

1¹/₁₆" Common Centerline / 36.5 mm Common Centerline

Part No.	Model	Drive Size	A (in.)	B (in.)	C (in.)	D (in.)	E (in.)	Max Torque (in. lbs.)
809504	SDRT - 1/4	1/4"	1 ⁷ / ₈	1 ³ / ₈	1 ⁵ / ₁₆	3/4	5/8	250
809505	SDRT - 3/8	3/8"	2	1 ¹ / ₂	1 ¹ / ₄	1	9/16	1250
809506	SDRT - 1/2	1/2"	2 ¹ / ₂	1 ³ / ₄	1 ¹ / ₄	1 ¹ / ₄	3/4	2500
809507*	SDRT - 3/4	3/4"	2 ³ / ₈	2	1 ¹ / ₂	1 ¹ / ₂	1	4800

*3³/₈" Common Centerline / 98.4mm Common Centerline

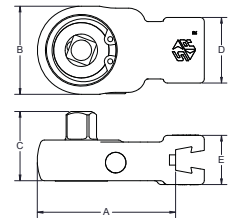

SMALL RATCHET BODY WITH LARGER DRIVE SIZE

1¹/₁₆" Common Centerline / 36.5 mm Common Centerline

Part No.	Model	Drive Size	A (in.)	B (in.)	C (in.)	D (in.)	E (in.)	Max Torque (in. lbs.)
853752	SDRT 1/4 with 3/8 Square Drive	3/8"	1 ⁷ / ₈	1 ³ / ₈	1 ⁵ / ₁₆	3/4	5/8	250
853395	SDRT 3/8 with 1/2 Square Drive	1/2"	2	1 ¹ / ₂	1 ¹ / ₄	1	9/16	1250
809508	SDRT 1/2 with 3/4 Square Drive	3/4"	2 ¹ / ₂	1 ³ / ₄	1 ¹ / ₄	1 ¹ / ₄	3/4	2500

SOCKET LOCK PIN

1¹/₁₆" Common Centerline / 36.5 mm Common Centerline

Part No.	Model	Drive Size	A (in.)	B (in.)	C (in.)	D (in.)	E (in.)	Max Torque (in. lbs.)
853304	SDRT 1/4 SOC LOCK PIN	1/4"	1 ⁷ / ₈	1 ³ / ₈	1 ⁵ / ₁₆	3/4	5/8	250
853305	SDRT 3/8 SOC LOCK PIN	3/8"	2	1 ¹ / ₂	1 ¹ / ₄	1	9/16	1250
853548	SDRT 1/2 SOC LOCK PIN	1/2"	2 ¹ / ₂	1 ³ / ₄	1 ¹ / ₄	1 ¹ / ₄	3/4	2500



HOLD & DRIVE SQUARE DRIVE RATCHET (SDRT)

1¹/₁₆" Common Centerline / 36.5 mm Common Centerline

Part No.	Model	Drive Size	Hole Size (in.)	Hex Key Size (in.)	A (in.)	B (in.)	C (in.)	D (in.)	E (in.)	Max Torque (in. lbs.)
853619	SDRT-1/4 with 1/8 hole	1/4"	1/8	3/32	1 ⁷ / ₈	1 ³ / ₈	1 ⁵ / ₁₆	3/4	5/8	250
853590	SDRT-1/4 with 9/64 hole	1/4"	9/64	1/8	1 ⁷ / ₈	1 ³ / ₈	1 ⁵ / ₁₆	3/4	5/8	250
853656	SDRT-3/8 with 1/8 hole	3/8"	1/8	3/32	2	1 ¹ / ₂	1 ¹ / ₄	1	9/16	1250
853246	SDRT-3/8 with 5/32 hole	3/8"	5/32	1/8	2	1 ¹ / ₂	1 ¹ / ₄	1	9/16	1250
853364	SDRT- 1/2 with 5/32	1/2"	5/32	1/8	2 ¹ / ₂	1 ³ / ₄	1 ¹ / ₄	1 ¹ / ₄	3/4	2500



RATCHET RENEWAL KITS

for all ratchet equipped torque wrenches and SDRT heads

Part No.	Description
816998	1/4" Ratchet Renewal Kit for ratchet 809504
816958	3/8" Ratchet Renewal Kit for ratchet 809505
816956	1/2" Ratchet Renewal Kit for ratchet 809506
816999	3/4" Ratchet Renewal Kit for ratchet 809507

RATCHETING OPEN END (ROE)

1¹/₆" Common Centerline / 36.5 mm Common Centerline

Slight disengagement from the fastener allows operator to rapidly rotate wrench.

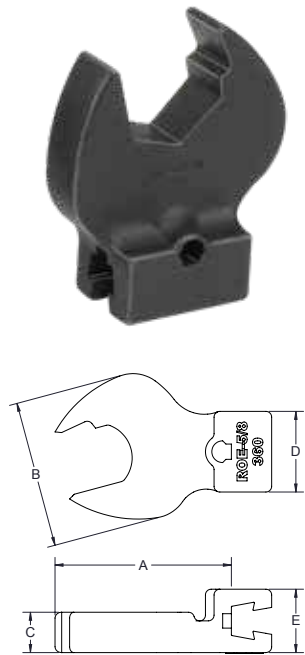

Part No.	Model	Hex Size (in.)	A (in.)	B (in.)	C (in.)	D (in.)	E (in.)	Max Torque (in. lbs.)
819201	ROE - 5/16	5/16	1 ⁴ / ₆₄	3/4	1/4	3/4	1 ¹ / ₁₆	90
819202	ROE - 3/8	3/8	1 ⁵ / ₈	1 ¹ / ₁₆	5/16	3/4	1 ¹ / ₁₆	120
819203	ROE - 7/16	7/16	1 ²³ / ₃₂	1 ¹ / ₁₆	5/16	3/4	1 ¹ / ₁₆	180
819204	ROE - 1/2	1/2	1 ²³ / ₃₂	1 ⁵ / ₁₆	1 ³ / ₃₂	3/4	1 ¹ / ₁₆	210
819205	ROE - 9/16	9/16	1 ²⁷ / ₃₂	1 ⁵ / ₁₆	1 ³ / ₃₂	3/4	1 ¹ / ₁₆	240
819206	ROE - 5/8	5/8	1 ²⁷ / ₃₂	1 ¹⁹ / ₃₂	7/16	3/4	1 ¹ / ₁₆	360
819207	ROE - 11/16	1 ¹ / ₁₆	1 ⁷ / ₈	1 ¹⁹ / ₃₂	7/16	3/4	1 ¹ / ₁₆	480
819208	ROE - 3/4	3/4	2	1 ²⁷ / ₃₂	1/2	1	1 ³ / ₁₆	600
819209	ROE - 13/16	1 ³ / ₁₆	1 ³¹ / ₃₂	1 ²⁷ / ₃₂	1/2	1	1 ³ / ₁₆	750
819210	ROE - 7/8	7/8	1 ³¹ / ₃₂	2 ¹ / ₈	1/2	1 ¹ / ₄	1 ¹³ / ₁₆	900
819211	ROE - 15/16	1 ⁵ / ₁₆	1 ⁶¹ / ₆₄	2 ¹ / ₈	1 ³ / ₃₂	1 ³ / ₁₆	1 ¹ / ₄	1050
819214	ROE - 1 1/8	1 ¹ / ₈	2 ¹⁹ / ₆₄	2 ¹ / ₄	1/2	1 ¹ / ₄	1 ¹ / ₄	1500

Part No.	Model	Hex Size (mm)	A (mm)	B (mm)	C (mm)	D (mm)	E (mm)	Max Torque (Nm)
819220	ROE-10 mm	10	43.18	27.94	7.62	20.32	17.78	13
819221	ROE-11 mm	11	43.18	27.94	7.62	20.32	17.78	20
819222	ROE-12 mm	12	45.72	33.02	7.62	20.32	17.78	23
819223	ROE-13 mm	13	45.72	33.02	7.62	20.32	17.78	23
819224	ROE-14 mm	14	45.72	33.02	7.62	20.32	17.78	27
819225	ROE-15 mm	15	45.72	40.64	7.62	22.86	17.78	27
819226	ROE-16 mm	16	45.72	40.64	7.62	22.86	17.78	40
819227	ROE-17 mm	17	45.72	40.64	7.62	22.86	17.78	54
819228	ROE-18 mm	18	45.72	40.64	7.62	22.86	17.78	54
819229	ROE-19 mm	19	48.26	45.72	10.16	25.4	20.32	68
819231	ROE-22 mm	22	50.8	53.34	10.16	33.02	20.32	101
819232	ROE-24 mm	24	50.8	53.34	10.16	33.02	20.32	118
819233	ROE-27 mm	27	53.34	58.42	12.7	33.02	20.32	152
819234	ROE-28 mm	28	53.34	58.42	12.7	33.02	20.32	170
819235	ROE-29 mm	29	58.42	71.12	12.7	33.02	20.32	152

SLIM PROFILE OPEN END (OE SPH)

1¹/₆" Common Centerline / 36.5 mm Common Centerline

Part No.	Model	Size (mm)	A (mm)	B (mm)	C (mm)	D (mm)	E (mm)	Torque Rating (Nm)
853912	OE-13 mm SPH	13	45.62	28.58	5.87	22.23	17.45	37 Nm
853913	OE-17 mm SPH	17	48.41	27.66	5.77	22.23	17.45	25 Nm
853871	OE-19 mm SPH	19	47.50	40.01	4.50	25.40	20.62	45 Nm
853872	OE-22 mm SPH	22	48.77	35.23	7.01	31.75	20.62	38 Nm
853873	OE-24 mm SPH	24	49.63	42.49	6.50	31.75	20.62	71 Nm
853874	OE-27 mm SPH	27	50.80	44.50	7.49	31.75	20.62	100 Nm
853875	OE-30 mm SPH	30	52.10	48.01	7.75	31.75	20.62	103 Nm
853914	OE-32 mm SPH	32	59.13	50.47	11.00	31.75	20.62	103 Nm
853876	OE-36 mm SPH	36	118.01	57.76	10.01	38.10	22.35	152 Nm
853877	OE-41 mm SPH	41	120.04	68.53	9.50	38.10	22.35	260 Nm
853923	OE-50 mm SPH	50	123.95	85.85	11.00	38.10	22.35	275 Nm



WARNING



- Do not exceed rated torque
- Do not use to break fasteners loose
- Periodic recalibration is necessary to maintain accuracy
- Read safety precautions on page 57

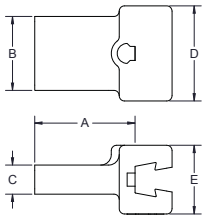

STANDARD TOOLING ADAPTERS

When fabricating special heads to be used with CCM torque handles other than Model CCM 300 and CCM 400, the $1\frac{7}{16}$ " / 36.5mm dimension must be maintained between the inside of the attachment block and the centerline of the wrench head. Model CCM 300 and CCM 400 are calibrated to $3\frac{7}{8}$ " / 98.4mm common centerline.

Part No.	Model	A (in.)	B (in.)	C (in.)	D (in.)	E (in.)	Max. Torque (in.lbs)
819901	STA - 1	$1\frac{5}{8}$	$\frac{9}{16}$	$\frac{11}{32}$	$\frac{3}{4}$	$\frac{11}{16}$	1600
819902	STA - 2	$1\frac{5}{8}$	$\frac{7}{8}$	$\frac{11}{32}$	$1\frac{1}{8}$	$\frac{13}{16}$	2500
809917	STA - 3	2	$1\frac{1}{2}$	$\frac{11}{32}$	$1\frac{1}{2}$	1	4800

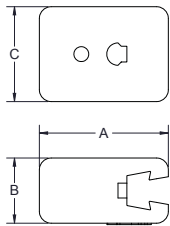

ADAPTERS FOR DIN STYLE HEADS

- Can be used to convert most DIN style heads to a female dovetail for use on all SR LTC series wrenches. Torque values should be set with the adapter and head attached to the wrench.
- Because of the variation in the length of the DIN plug type heads, it is not recommended that this adapter be used with CCM micrometer adjustable wrenches.

Part No.	Model	A (in.)	B (in.)	C (in.)
819136	Adapter, 9mm x 12mm	$1\frac{23}{64}$	$1\frac{1}{16}$	1
819137	Adapter, 14mm x 18mm	$1\frac{23}{64}$	$1\frac{1}{4}$	$\frac{13}{16}$

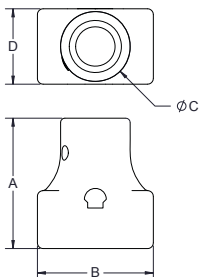

ADAPTERS FOR ROUND STYLE HEADS

- Can be used to convert most round style heads to a female dovetail for use on all SR LTC series wrenches. Torque values should be set with the adapter and head attached to the wrench.
- Because of the variation in the length of the round plug type heads, it is not recommended that this adapter be used with CCM micrometer adjustable wrenches.

Part No.	Model	Description	A (in.)	B (in.)	C (in.)	D (in.)	Max. Torque (in. lbs.)
853021	BAJ	"J" size female-female dovetail	$1\frac{13}{32}$	$1\frac{1}{4}$	$\frac{3}{4}$	$\frac{13}{16}$	2500
853022	BAY	"Y" size female-female dovetail	$1\frac{13}{32}$	$1\frac{1}{4}$	$\frac{3}{4}$	$\frac{13}{16}$	2500

RATCHETING FLARE NUT (RFN)

1⁷/₁₆" Common Centerline / 36.5 mm Common Centerline
Single-direction ratchet for use with hydraulic or pneumatic fittings.

Part Number	Model	Size (mm)	A (mm)	B (mm)	C (mm)	D (mm)	E (mm)	Max. Torque (Nm)
819086	RFN-10 mm	10	50.8	7.62	15.24	22.86	17.78	45
819087	RFN-11 mm	11	50.8	7.62	15.24	22.86	17.78	45

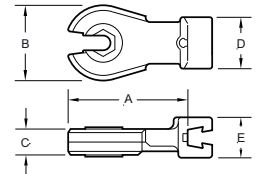

RATCHETING TUBE WRENCH

Part No.	Model	Size (in.)	A (in)	B (in)	C (in)	D (in)	E (in)	Max Torque (in lb)
853156	RTW-11/16	1 ¹ / ₁₆	3 ³ / ₄	1 ³ / ₁₆	5 ⁵ / ₁₆	1 ¹ / ₈	1 ³ / ₁₆	750

Part No.	Model	Size (mm)	A (mm)	B (mm)	C (mm)	D (mm)	E (mm)	Max Torque (Nm)
853166	RTW-17mm	17	94.74	33.53	9.65	28.58	20.64	84.74

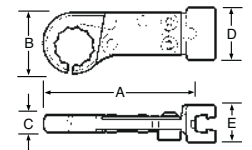

Caution: The configuration of the ratcheting tube wrench makes keeping our common centerline approach next to impossible to maintain. When setting torque value on an LTC wrench in conjunction with an RTW head, set the torque value using the model designation head that is to be used. When you change to a different RTW size, verify torque output.

LTCE-SERIES & LTCE-15 SERIES Straight & 15 Degree Angled Extension

Part No.	Model	Angle (degrees)	A (in.)	B (in.)	C (in.)	D (in.)	Max. Torque (in. lbs)
819424	LTCE - 4	0	4	1 ¹ / ₈	3 ³ / ₈	1 ¹ / ₈	300
819467	LTCE - 6	0	6	1 ¹ / ₄	3 ³ / ₈	1 ¹ / ₈	800
819487	LTCE - 4 - 15	15	4	1 ¹ / ₈	3 ³ / ₈	1 ¹ / ₈	300
819504	LTCE - 6 - 15	15	6	1 ¹ / ₄	3 ³ / ₈	1 ¹ / ₈	800



Do not use these with CCM-Series torque wrenches.
Preset the torque wrench after the extension and fastener engagement head have been attached to the tool.

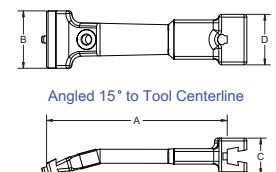
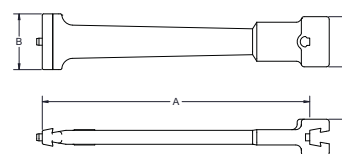

HEX DRIVE (HD)

1/16" Common Centerline / 36.5 mm Common Centerline

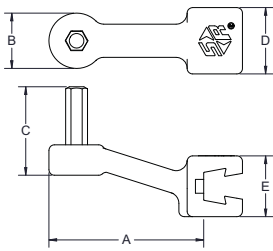

Part No.	Model	Size (in.)	A (in.)	B (in.)	C (in.)	D (in.)	E (in.)	Max. Torque (in. lbs.)
819687	HD-3/32	3/32	1.7	0.5	0.8	0.8	0.8	30
819689	HD-1/8	1/8	1.7	0.5	0.8	0.8	0.8	70
853032	HD-9/64	9/64	1.7	0.5	0.8	0.8	0.8	70
819691	HD-5/32	5/32	1.7	0.5	1.0	0.8	0.8	135
819692	HD-3/16	3/16	1.7	0.5	1.0	0.8	0.8	235
819693	HD-7/32	7/32	1.8	0.6	1.0	0.8	0.8	340
819694	HD-1/4	1/4	1.8	0.6	1.0	0.8	0.8	450
819695	HD-5/16	5/16	1.8	0.8	1.0	0.8	0.8	850
819696	HD-3/8	3/8	1.8	0.8	1.0	0.8	0.8	850
819701	HD-3/4	3/4	2.2	1.4	2.0	1.3	0.9	2400
819702	HD-7/8	7/8	2.2	1.5	2.0	1.3	0.9	2700

Part No.	Model	Size (mm)	A (mm)	B (mm)	C (mm)	D (mm)	E (mm)	Max. Torque (Nm)
809315	HD-4 mm	4	43.18	12.70	25.40	20.32	2.32	14
809316	HD-5 mm	5	43.18	12.70	25.40	20.32	20.32	27
809317	HD-6 mm	6	45.72	15.24	25.40	20.32	20.32	37
809328	HD-8 mm	8	45.72	20.32	25.40	20.32	20.32	95
809330	HD-10 mm	10	48.26	25.40	25.40	22.86	20.32	141

CROWFOOT ADAPTER

- Gain the significant advantage of our interchangeable head system by attaching the SRA to any fixed square drive wrench.
- Ideal for use when a direct reading torque wrench is required but space is limited.
- Use of an adapter requires calculation of torque output.
- When used with our 1 7/16" / 36.5mm Interchangeable Heads the adapter length will be 3" or 76.2mm.



Part No.	Model	Description
850653	SRA-3/8	3/8 Female-Male Dovetail
850655	SRA-1/2	1/2 Female-Male Dovetail

WESTEC[®] - Sales & Services In India

Office No. 12, 1st Floor, Hermes Atrium,
B wing, Plot 57, Sector – 11,
CBD Belapur, Navi Mumbai – 400 614

Mob: 9821 0327 20 | Tel:+91-22-2756 6533
Telefax: +91-22-2756 6534 | Website - <http://westec-india.com/>
E-mail: westecnavimumbai@vsnl.net